



French manufacturer of food, coffee, bar and juice equipment

An SME business using The Hague System

Santos : Made in France, exported worldwide



130 countries



*65 years of experience
all around the world*
*Une expérience enrichie
depuis 65 ans à travers le monde*

Santos world tour
Le tour du monde Santos

A Santos product for every need,
everywhere in the world.
Un produit Santos pour chaque besoin,
partout dans le monde.

Spain
Gazpacho

United States
Food coffee frappe

Morocco
Orange juice

Brazil
caipirinha

France
Espresso

Slang Slang
Carrot Juice

Australia
Coffee



- 📎 ... All our products are **designed and assembled in Santos** headquarters in Lyon.
- 📎 Professional equipment : Worldwide **B to B Market** - 80% export – 130 Countries
- 📎 SME business – 50 people – 20M€ annual turnover – family owned

- Santos was **created in 1954** by André Fouquet, to provide **commercial electrical equipment** to bars, restaurants, hotels, coffee shops, juice bars...
- A worldwide trademark synonymous of **reliable and sturdy** products.

The trademark :



via **WIPO** since **1988 ! (Madrid treaty)**

SANTOS ADVENTURE

1954
The beginning

1st
Trade show and 1st Advertisements

80's

90's

20-00's

20-10's

65 years of history

Today

Aurelien & Nicolas Fouquet
Join Santos

The collage features various images: a 1954 office scene, a trade show booth, product advertisements, a group photo from the 80s, a 90s trade show booth, a 20-00s group photo, a 20-10s trade show booth, and a 'Today' photo of Aurelien and Nicolas Fouquet holding a certificate. A central circular graphic contains the text 'Aurelien & Nicolas Fouquet Join Santos'.

Some of the Santos best sellers :



Citrus juicer
« Classic » N°11



« Silence » Coffee grinders
N°40A and 55



Juicers N°50 and 68



Blender N°62



Full Juice Bar Solution



FOOD AND BEVERAGE SOLUTIONS PROVIDER

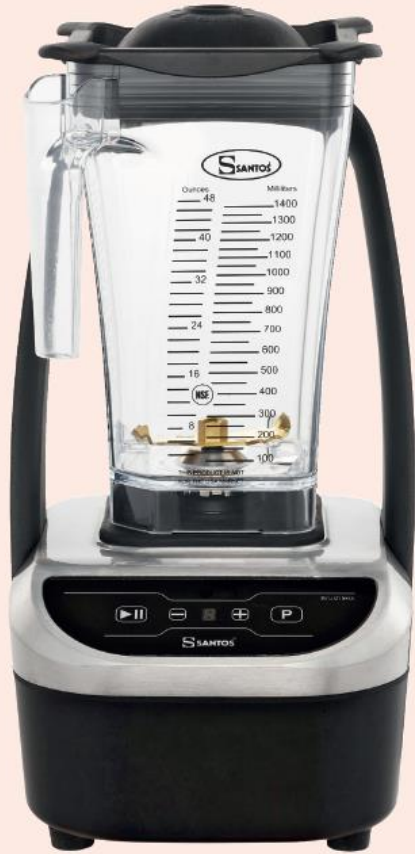

New!

COMPACT BRUSHLESS BLENDER #66

Available
from June 2021
Pre-order now!



www.blender66.fr



Worldwide network

and experience

- Santos is represented in more than 130 countries
- We participate in the most important tradeshows all over the world



Milan



Moscow



Chicago



Dubai



Singapore

B to B Promotion :

- Tradeshows : Milano, Shanghai, Dubai, Chicago, Moscow, Singapour, Hong-Kong, and many others, directly by Santos or with his importers



DUBAI

- Professional press



THE BRUSHLESS TECHNOLOGY
 Long lifetime
 Extremely Quiet
 Two way rotation
 Excellent energy efficiency
 No maintenance

BRUSHLESS BLENDER #62
 The first brushless blender in the world

www.santos.fr - santos@santos.fr

S SANTOS



INFATIGABLE
depuis 1954

SIRHA - STAND 6A94
www.santos.fr

S SANTOS



S SANTOS

The best ON Juicer
THE MARKET

JUICE EXTRACTOR #68

YOUR JUICE PARTNER SINCE 1954

Come & see us
NAFEM, ORLANDO
 stand #4710

www.santos.fr

Santos products are all around the world!

SANTOS ADDICTS



Hong-Kong



Indonesia



Argentina



Sweden



Denmark

Connect with us!



@SantosAddict

Santos S.A.S.



Greece



Austria



Ivory Coast



Italy



Korea

Santos Juice bar solution in chains



To work with bigger than you, better be protected by IP right

Our History of IP



1960's – The technicians want to protect their inventions !

Patents



1980's – The worldwide salesman want to protect the brand !

Trade Marks



2000's – The nice designed products have to be unique !

Designs

2020's – Exist in the globalization in front of big groups

Global IP

Why do we use IP ?

- **A Strategy, an investment, which can be easy to use and cost effective even for SME businesses. A long time oriented asset.**
- **Protection of our inventions worldwide**

We protect :

**New inventions
= Technical
Patents**



**Designs
= Design
Patents**



Our Brand



- 📎 Santos strategy :
 - 📎 10% of our annual turnover is invested in R&D
 - 📎 1 new product every 1 or 2 years (including restyling)
 - 📎 **Each new product has an Industrial Design patent**



... because we want it to be unique !

Competitors having the same technology / performances, will at least have a different look !

A tool for “fair competition”

IP timing :

- **Protect the product before showing it**
- **Develop quickly the sales, and worldwide**
- **Decide about the international extensions before 6 months**

French patent office link to WIPO website for international Design :

Le dessin ou modèle international

Par une demande unique auprès de l'Organisation mondiale de la propriété intellectuelle (OMPI), vous pouvez demander une protection dans un ou plusieurs pays membres de l'Arrangement de La Haye. Le dépôt se fait directement auprès de l'OMPI car l'INPI ne peut recevoir les dépôts internationaux. La demande internationale peut être déposée en français, en anglais ou en espagnol et donne lieu au paiement d'une taxe unique. L'enregistrement est publié en français, en anglais et en espagnol.

› Site de l'OMPI

<https://www.inpi.fr/fr/valoriser-vos-actifs/faire-vivre-votre-dessin-ou-modele/se-proteger-l-etranger>

Our Juicer no 50 from 2002

Hague
D058631
Juice extractors
2002-01-21
SANTOS (SOCIÉTÉ PAR ACTIONS SIMPLIFIÉE)



(81) Designated Contracting Parties

II. BX, CH, DE, GR, IT, MA

<https://www.wipo.int/designdb/en/index.jsp#>

Our Juicer no 68 from 2014

Hague
D083063
1. Electric juicer
2014-03-07
SANTOS (SOCIÉTÉ PAR ACTIONS SIMPLIFIÉE)



(81) Designated Contracting Parties

II. MA III. SG, TN, TR

<https://www.wipo.int/designdb/en/index.jsp#>

Industrial Designs - The Hague System

- 📎 We file in via our **Patent Attorney**, for global IP Strategy (Patents, Designs, Brands)
- 📎 Be one step further, **protect the investments**, keep the market monopole
- 📎 Protecting the business of our **distributors** worldwide (a sales tool), they ask us to fight against unfair competition. Our market is their market.
- 📎 Industrial Designs are **very dissuasive** :
 - 📎 Very often used for **letters of formal notice** (With our international **Lawyers**)
 - 📎 (Hopefully) No trial in our history (trials only occurred on technical patents)

- 📎 “Copyrights” is not strong enough worldwide? It is the last solution for very old products (more than 20 years), and only against purely servile counterfeits



SANTOS® Industrial Designs - The Hague System

Hague Union Members

75 Members (including European Union and OAPI)
covering 92 countries (on July 19, 2021)

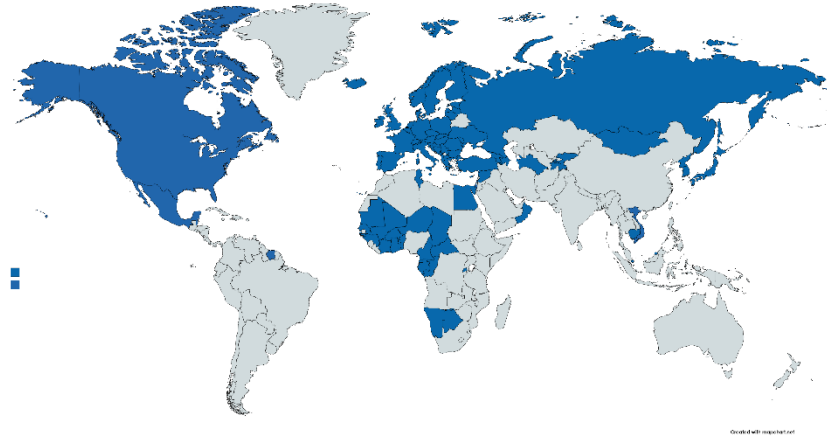

- Advantages of The Hague System :
 - Better **cost efficiency** / budgets
 - Easier and centralized **portfolio management**
- High interest for **new members** in the system (Japan, South Korea, USA...)

... for a «worldwide» protection of our products

Source : WIPO

Example on the new Blender no66 : Exploded view showing all spare parts is already available freely

Brand

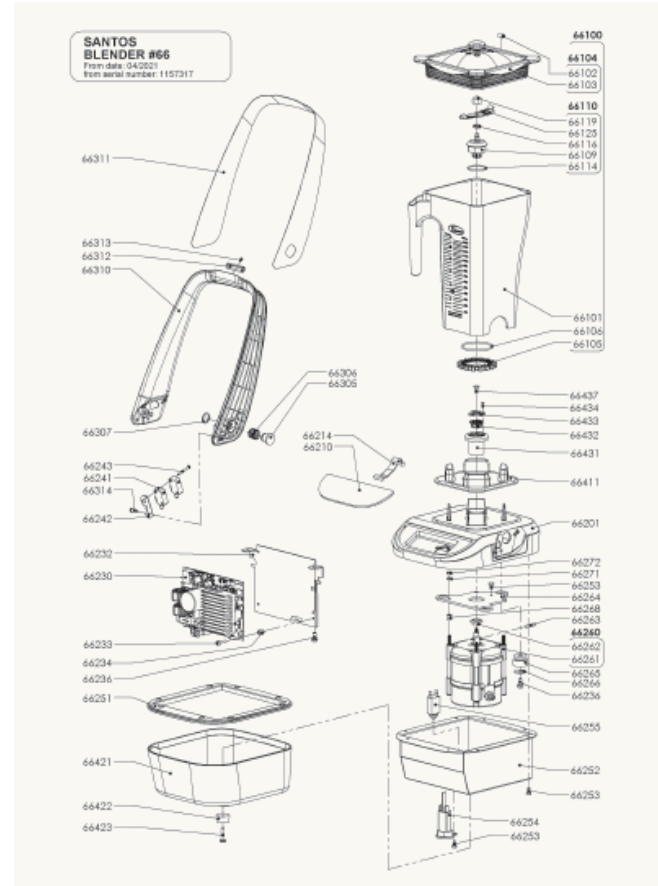

Model



Technical patent

📎 Example on the Blender no62 :

Current Status

Registration under 1999 Act	
(11) International Registration Number	DM/073 524
(15) Date of the international registration	14.04.2010
(18) Expected expiration date of the registration/renewal	14.04.2020
(22) Filing date	14.04.2010
(73) Name and address of the holder(s)	SANTOS (SOCIÉTÉ PAR ACTIONS SIMPLIFIÉE) 140-150, avenue Roger Salengro, F-69120 VAULX-EN-VELIN (FR)

(81) Designated Contracting Parties

📍 II. MA III. SG, TR



<http://www.wipo.int/designdb/hague/en/>



When you are copied, it may be the price of success... ... or it is too late...



Peut-on avoir raison de la contrefaçon ?

3 – Les victoires de SANTOS dans la lutte contre la contrefaçon



VRAI

FAUX

FAUX

FAUX



One slide from the presentation to the French Authorities made by Nicolas FOUQUET, SANTOS, in 2010, about the fight against counterfeits

Better prevent by filing...

**SMEs, Startups from small countries, let your innovations conquer the world !
= a positive globalization**

Thank you for your attention

Nicolas FOUQUET
CEO – General Manager
SANTOS – Vaulx-en-Velin – France
www.santos.fr
nfouquet@santos.fr