

AL-INVEST Verde 



DERECHOS DE PROPIEDAD INTELECTUAL



LATIN AMERICA

CASOS PRÁCTICOS DE EXAMEN DE DIBUJO O MODELO COMUNITARIO

Carlos Mateo y Mar Portillo | ALICANTE | 12-03-2024



Proceso de examen

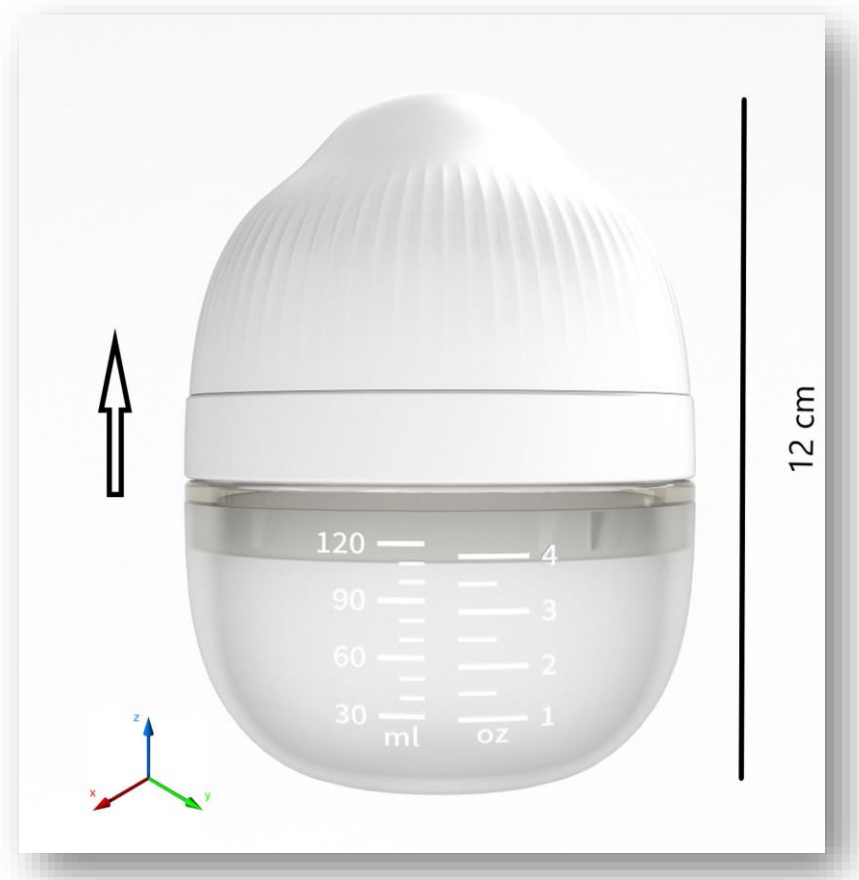

Proceso de examen



Proceso de examen



Proceso de examen

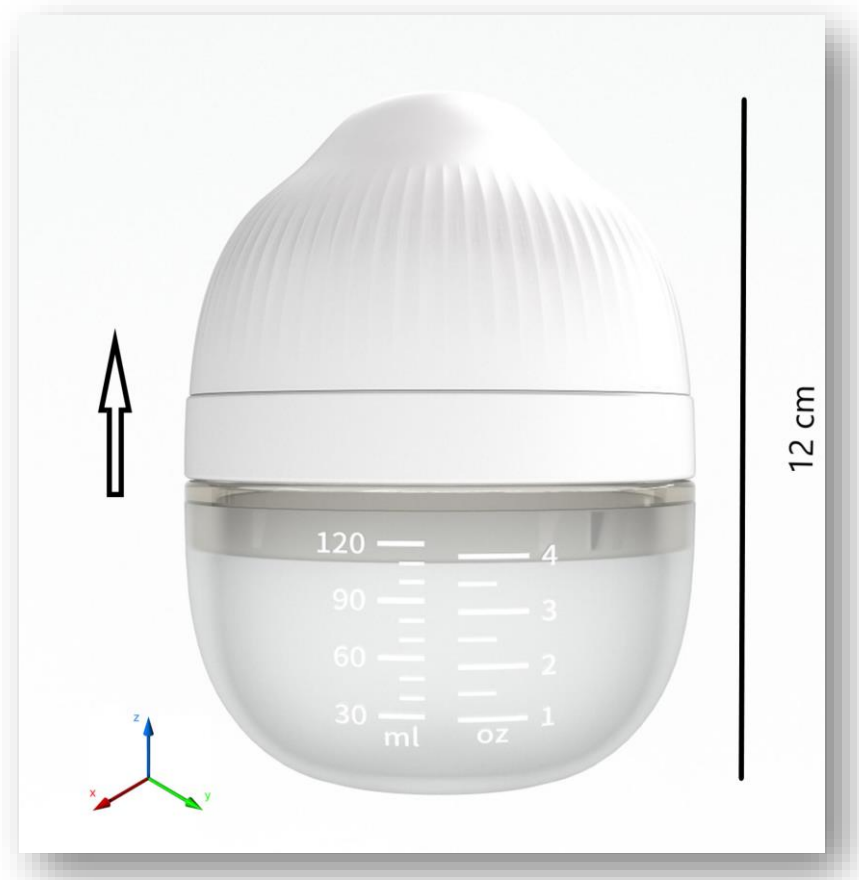

SÍMBOLOS, LÍNEAS, NÚMEROS O TEXTO EN LA REPRESENTACIÓN

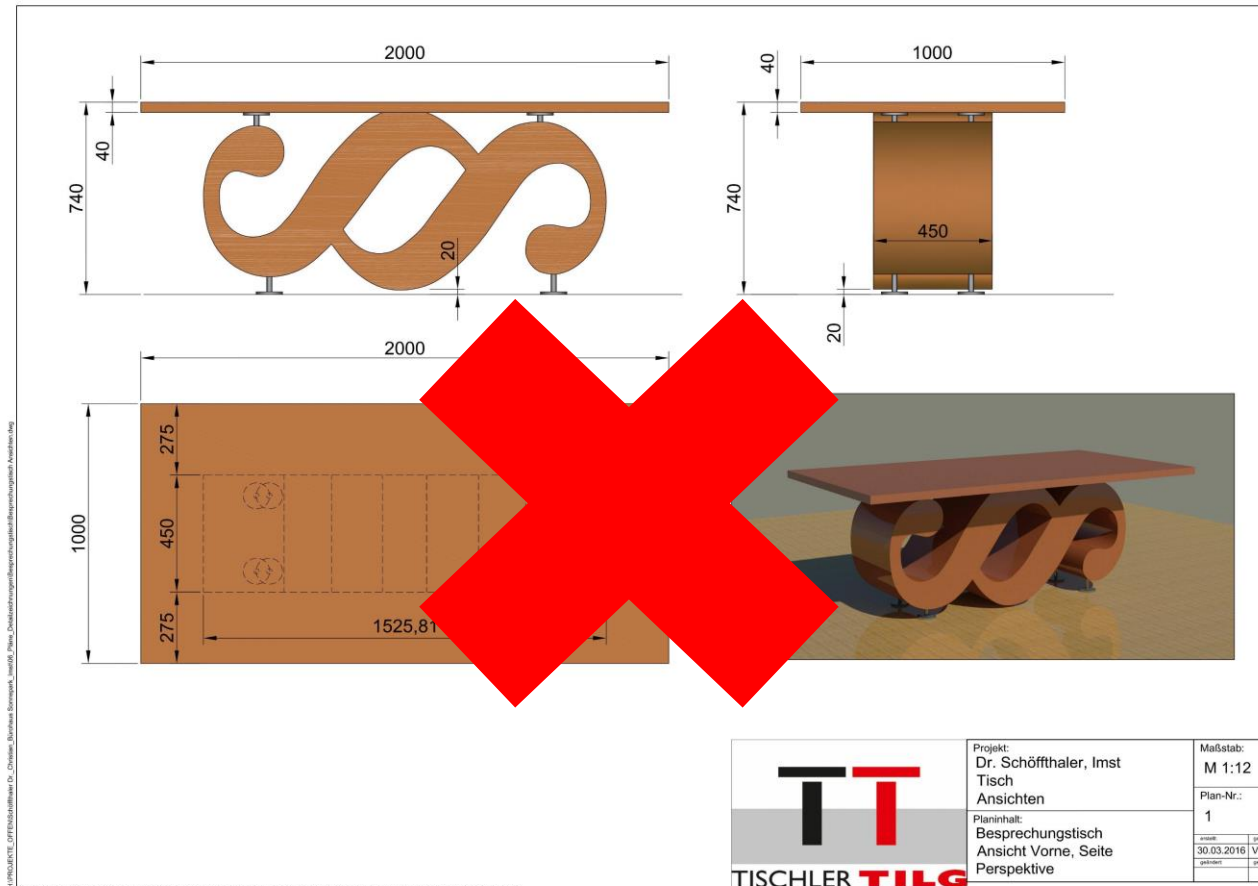

H:\PRODUKTE_LIEFERANTEN\01_CHEMIE_Bornhaus Bornspeck_Imst\08_Druckunterlagen\Baugruppenelemente\Besprechungstisch_Anworten.dwg

Pläne, Skizzen und sonstige technische Unterlagen sind unser geistiges Eigentum und dürfen nur mit unserer Zustimmung ververviältigt oder an Dritte weitergegeben werden.

CONSISTENCIA



CONSISTENCIA



CONSISTENCIA

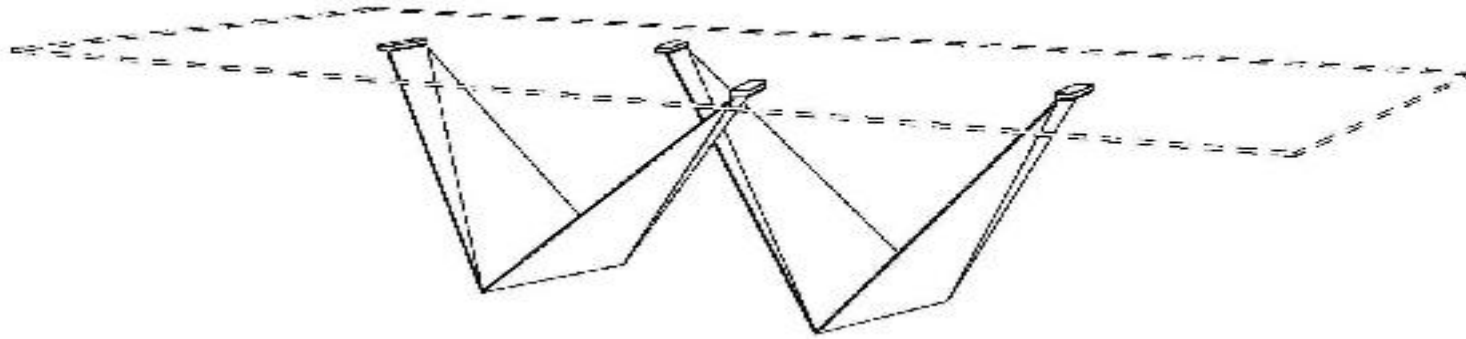

Indicación de producto:
“Patas de mesa”

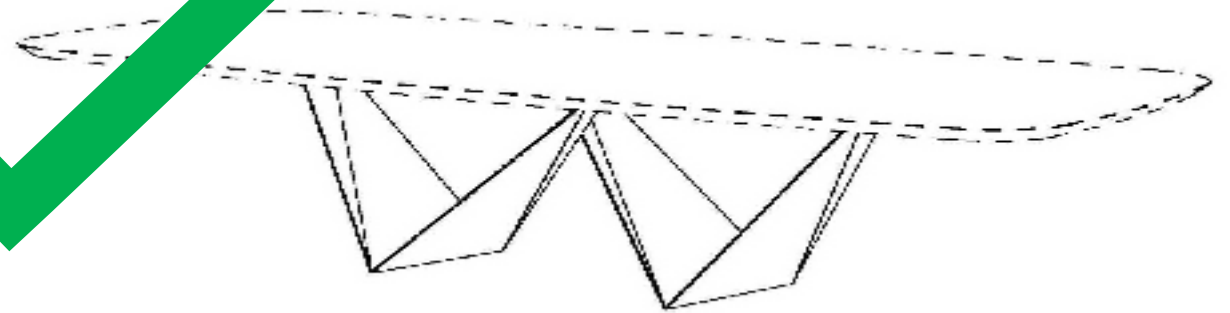

¿Mismo diseño?

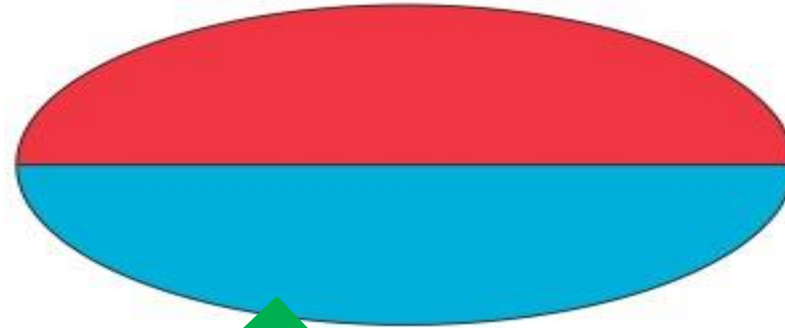
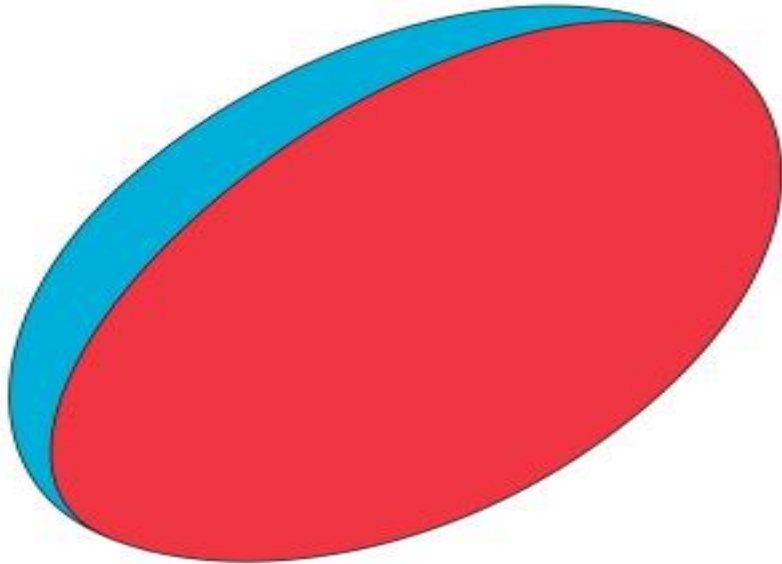

CONSISTENCIA

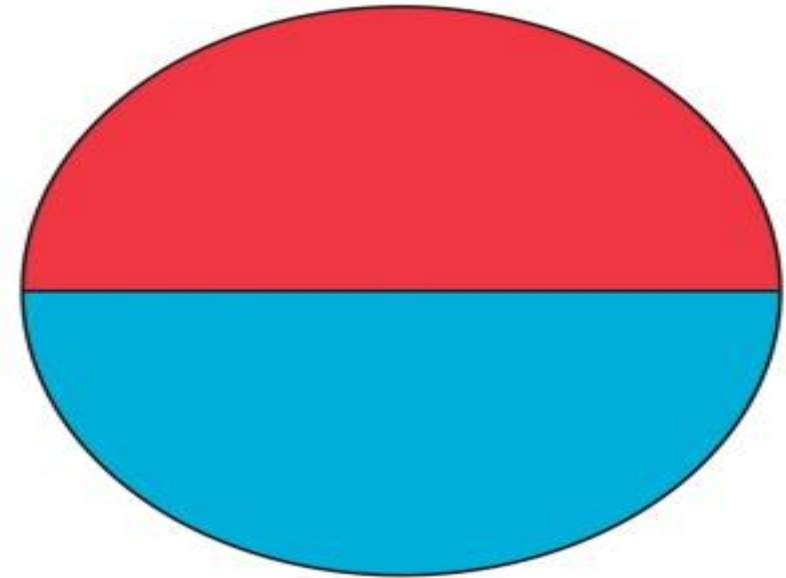
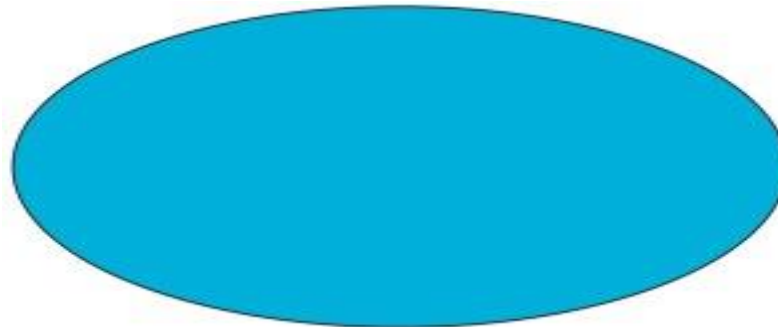
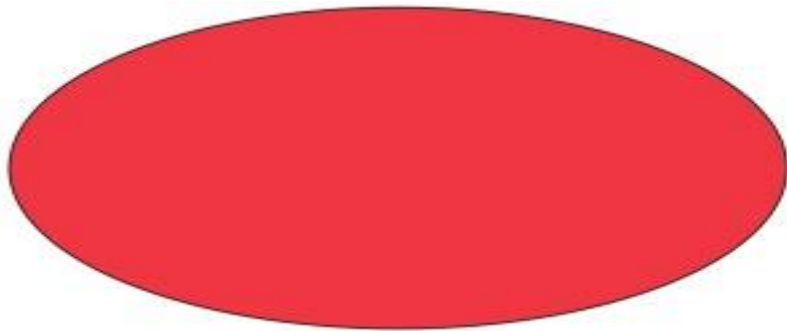

Indicación de producto:
"Juguetes"
¿cómo diseño?



CONSISTENCIA DE LAS VISTAS

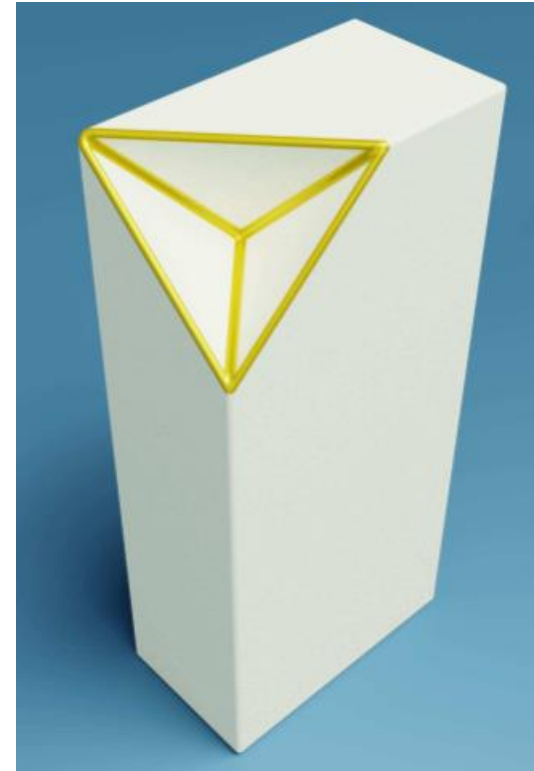
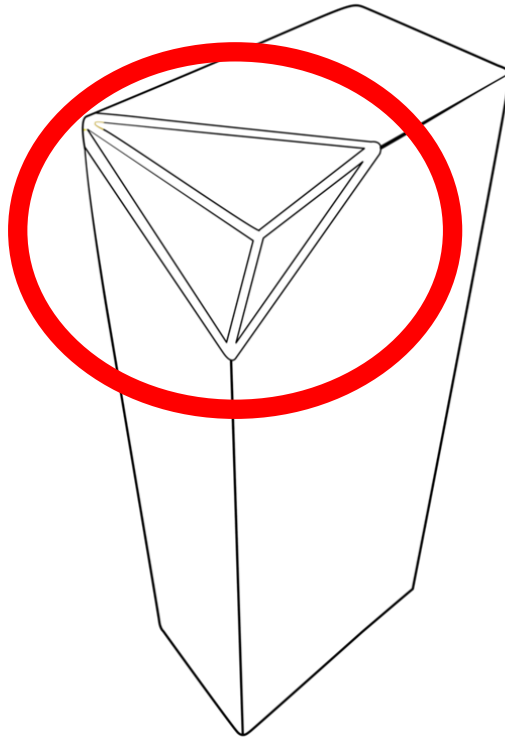

CONSISTENCIA DE LAS VISTAS

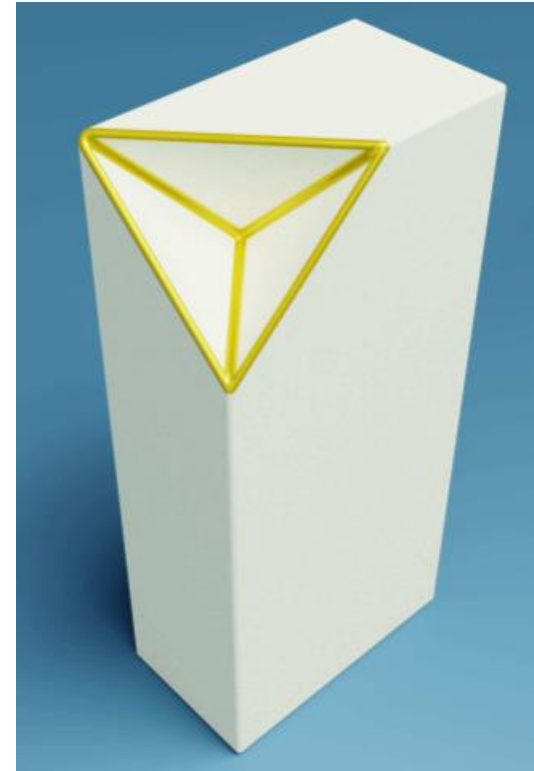
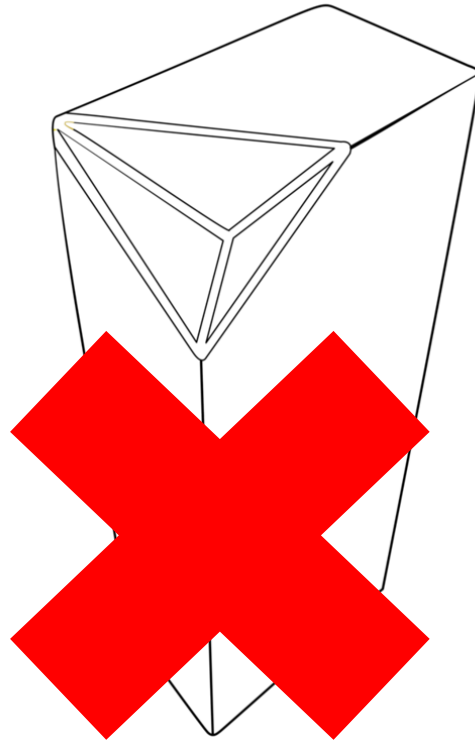

CONSISTENCIA DE LAS VISTAS

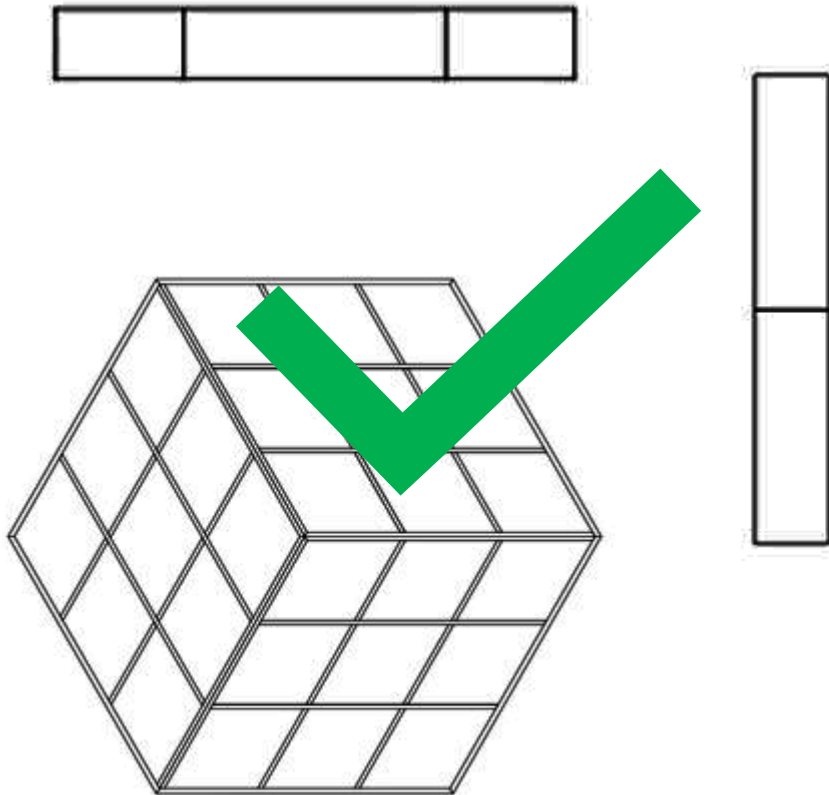

Indicación de producto:
“Estante de pared”

¿Mismo diseño?

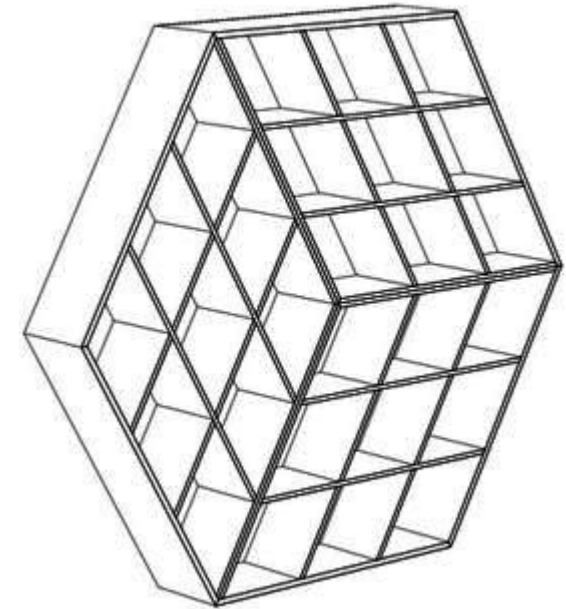

CONSISTENCIA DE LAS VISTAS

Indicación de producto:
“Perfiles de construcción”

¿Mismo diseño?

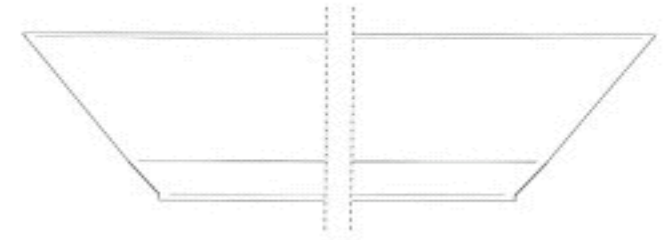
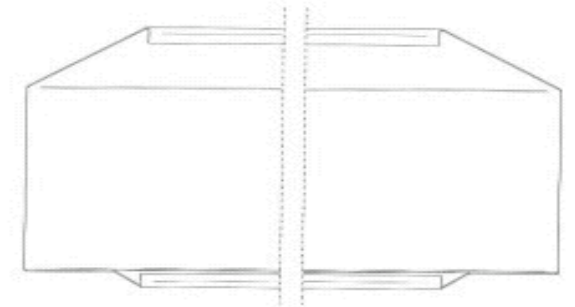
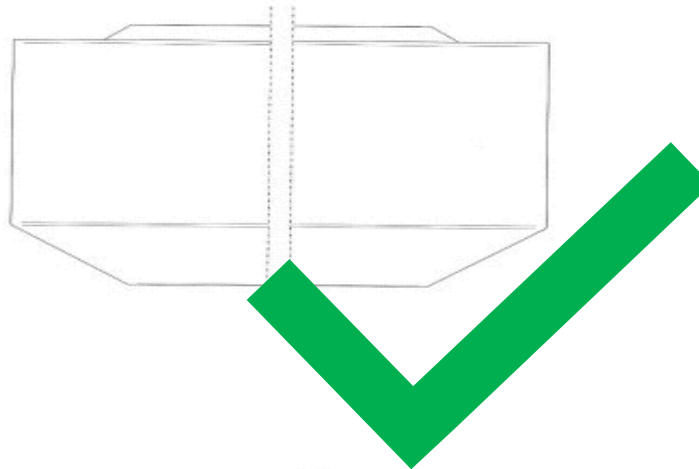

CONJUNTOS DE PRODUCTOS



CONJUNTOS DE PRODUCTOS

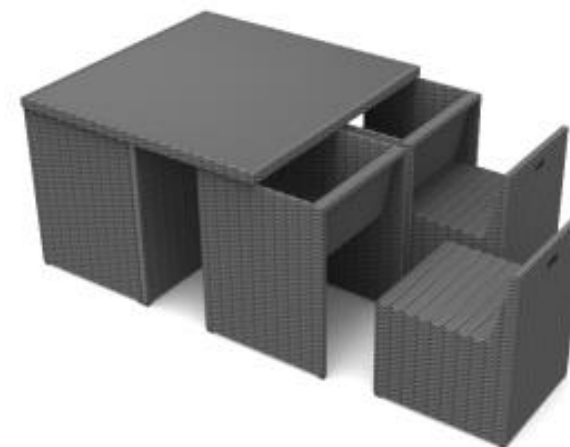
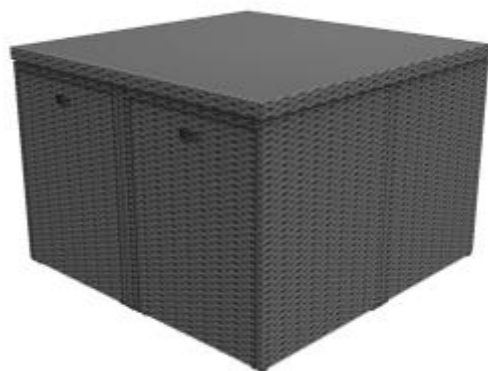
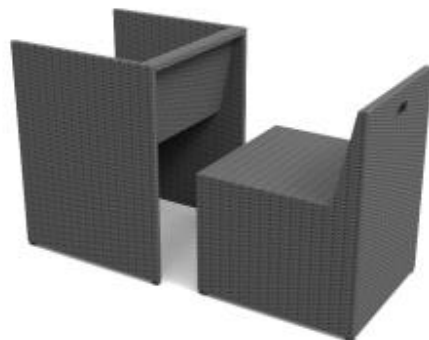
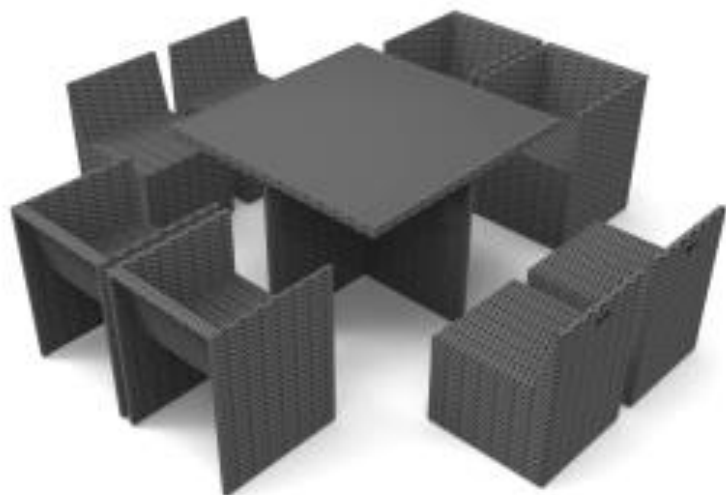

FONDO NEUTRO (ENTORNO VACÍO) Y RENUNCIAS

Indicación de producto:
“Baldosas para suelos”

Clase de Locarno:
25-01

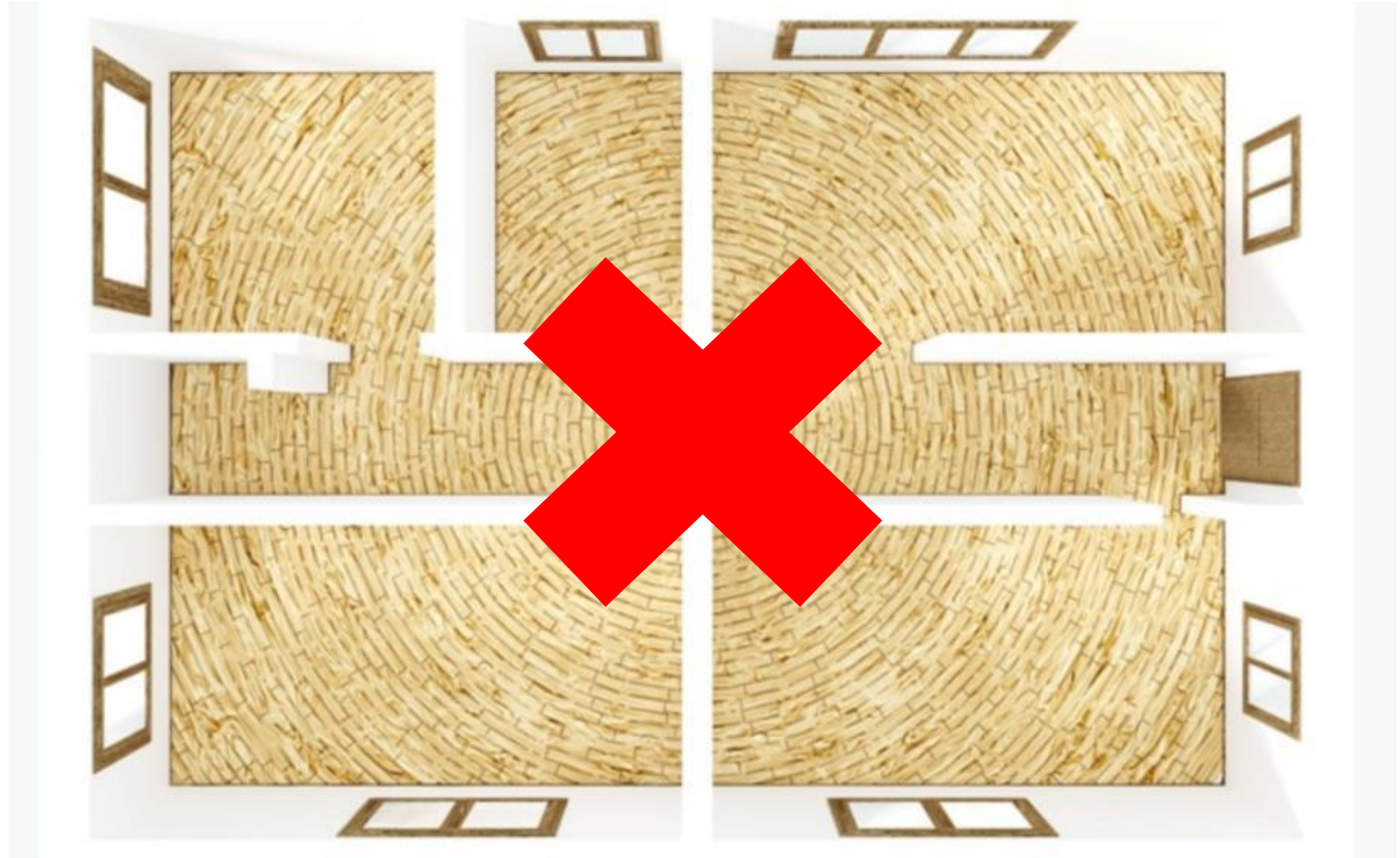

FONDO NEUTRO (ENTORNO VACÍO) Y RENUNCIAS

Indicación de producto:
“Baldosas para suelos”

Clase de Locarno:
25-01



FONDO NEUTRO (ENTORNO VACÍO) Y RENUNCIAS

Indicación de producto:
“Baldosas para suelos”

Clase de Locarno:
25-01



FONDO NEUTRO (ENTORNO VACÍO) Y RENUNCIAS

Indicación de producto:
“Estantes de exposición”

Clase de Locarno:
20-02

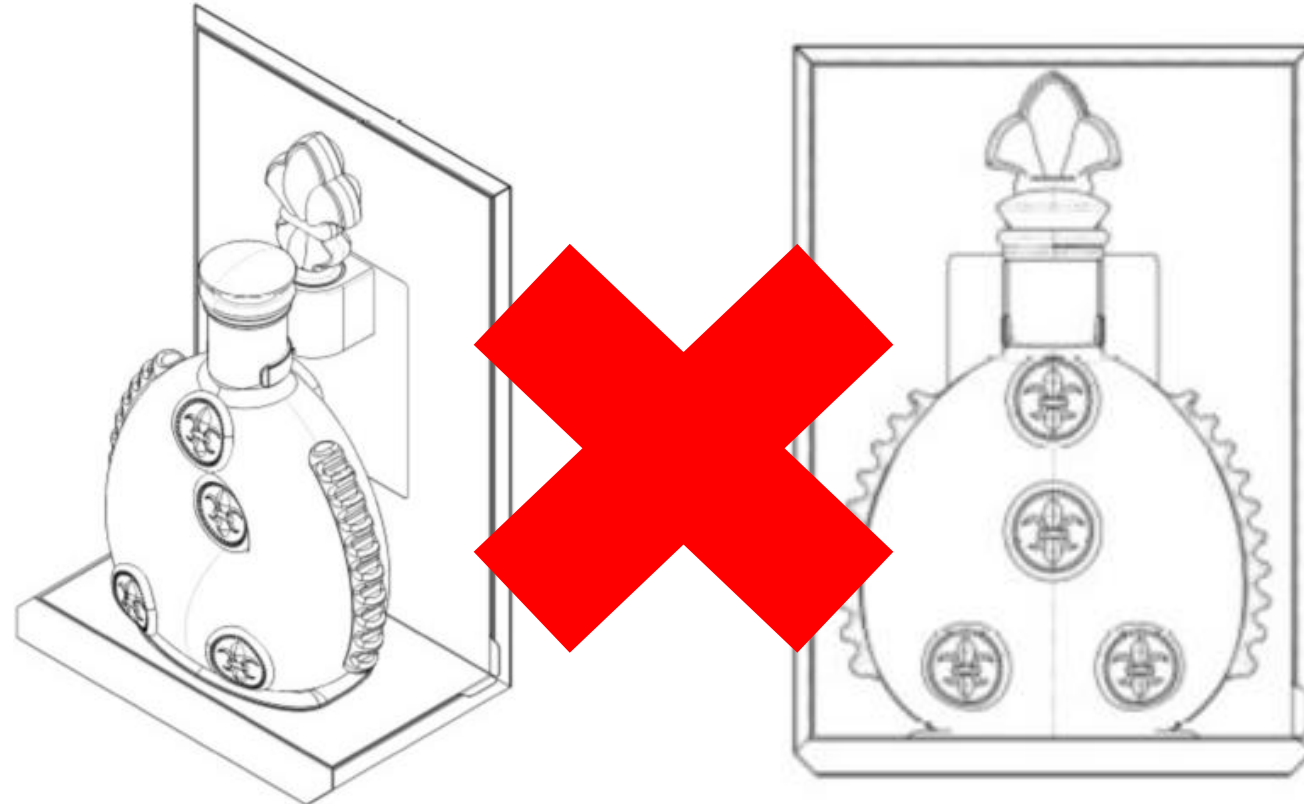

FONDO NEUTRO (ENTORNO VACÍO) Y RENUNCIAS

Indicación de producto:
“Estantes de exposición”

Clase de Locarno:
20-02

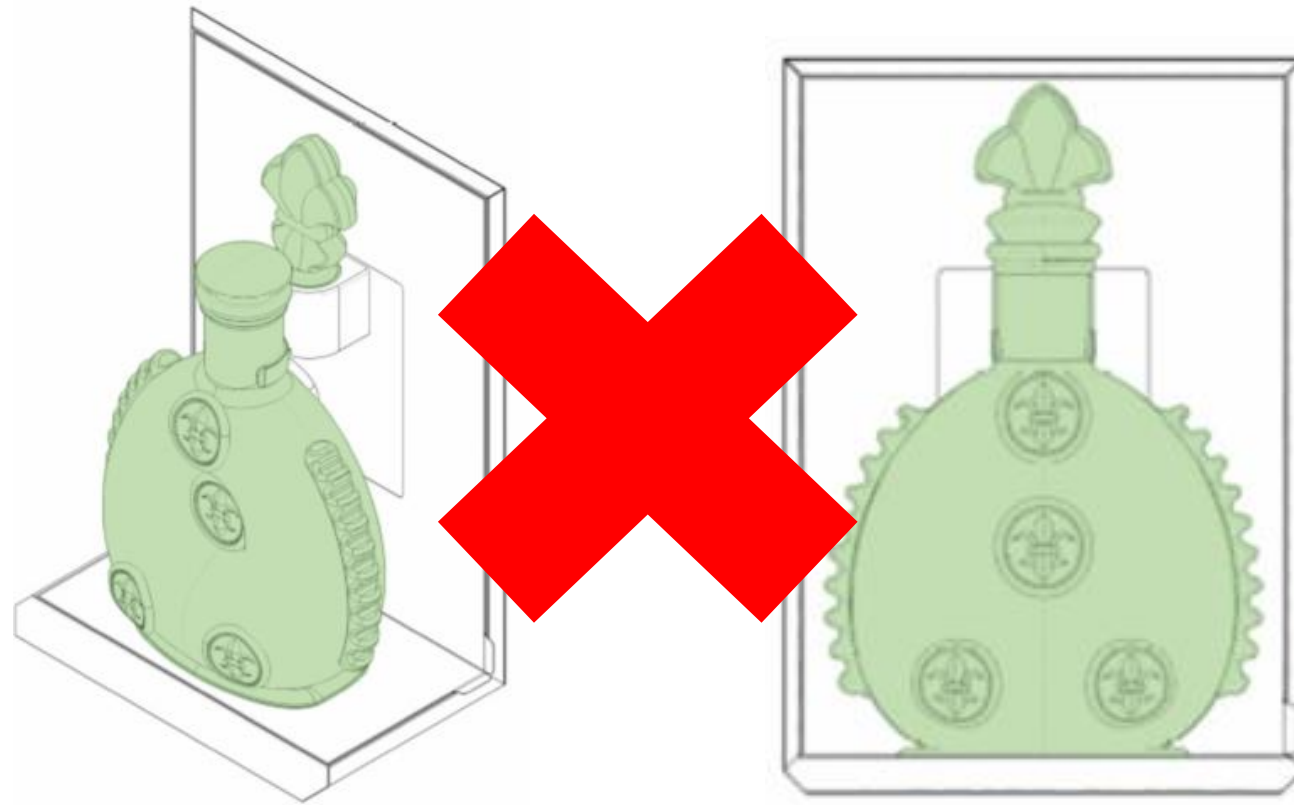

FONDO NEUTRO (ENTORNO VACÍO) Y RENUNCIAS

Indicación de producto:
“Estantes de exposición”

Clase de Locarno:
20-02

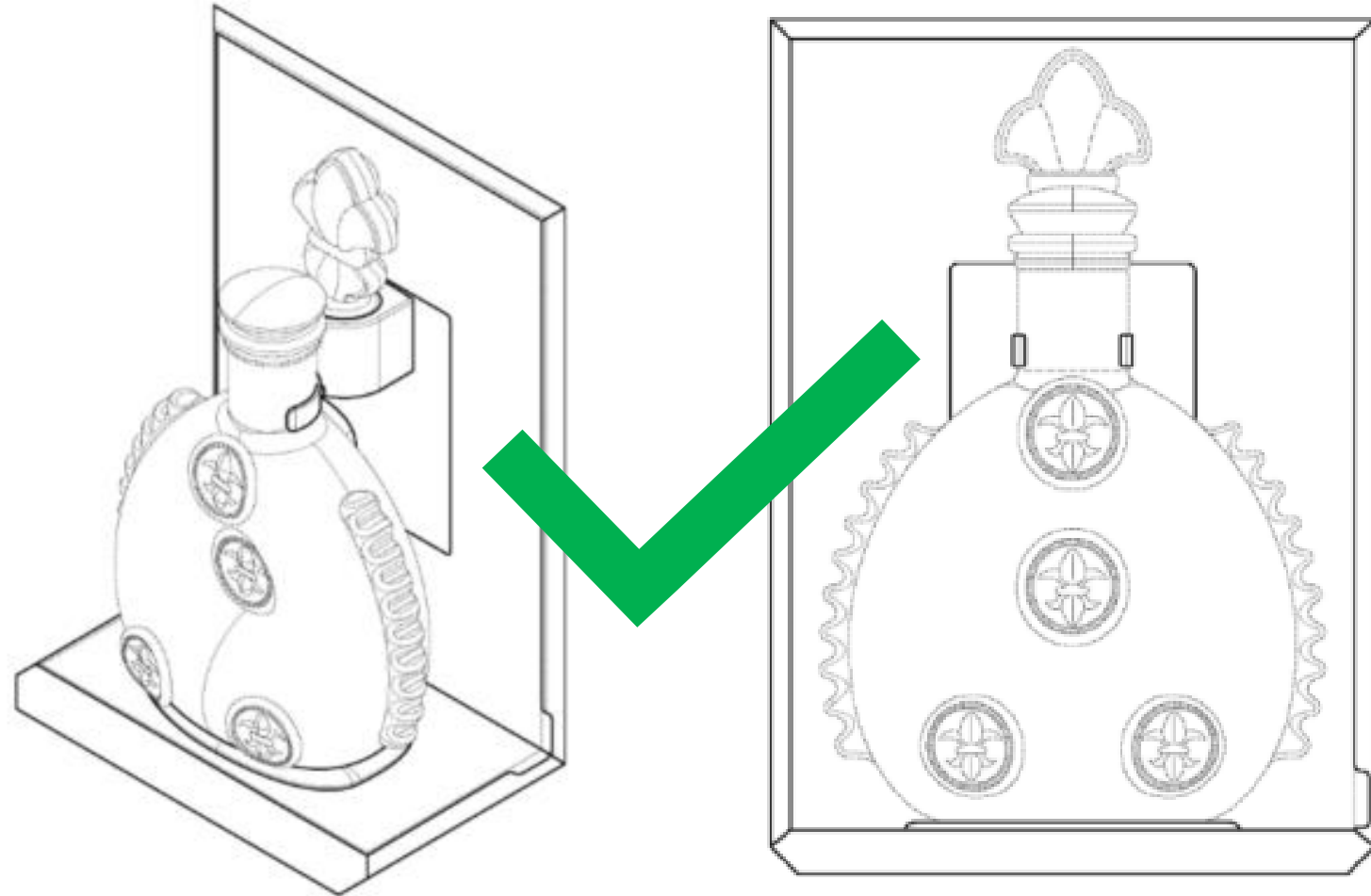

FONDO NEUTRO (ENTORNO VACÍO) Y RENUNCIAS

Indicación de producto:
“Tops (ropa)”

Clase de Locarno:
02-02



FONDO NEUTRO (ENTORNO VACÍO) Y RENUNCIAS

Indicación de producto:
“Tops (ropa)”

Clase de Locarno:
02-02



DEFICIENCIAS COMBINADAS

Indicación de producto:
“Teteras”

¿Cuántas deficiencias?



AL-INVEST Verde 



DERECHOS DE PROPIEDAD INTELECTUAL

 IPKey

LATIN AMERICA

¡GRACIAS!

maria.portillo@euipo.europa.eu

carlos.mateo@euipo.europa.eu



Financiado por la Unión Europea

